

rotork®

Keeping the World Flowing
for Future Generations

CK Range

Multi-turn • Part-turn • Control Systems
Modular Design Electric Valve Actuators



CK
range

Reliability in critical flow control applications

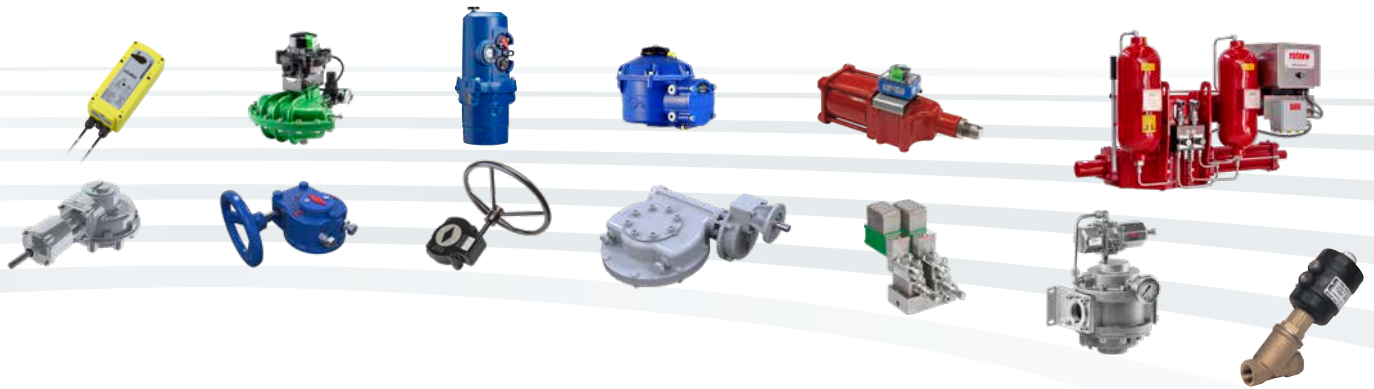

Reliable operation when it matters

Assured reliability for critical applications and environments. Whether used 24/7 or infrequently, Rotork products will operate reliably and efficiently when called upon.

Quality-driven global manufacturing

Products designed with 60 years of industry and application knowledge.

Research and development across all our facilities ensures cutting edge products are available for every application.

Customer-focused service worldwide support

Solving customer challenges and developing new solutions. From initial enquiry through to product installation, long-term after-sales care and Client Support Programmes (CSP).

Low cost of ownership

Long-term reliability prolongs service life.

Rotork helps to reduce long term cost of ownership and provides greater efficiency to process and plant.

CK Range

Section	Page	Section	Page
Intelligent Modular Design	4	Electrical Connections	26
Introduction	6	Mechanical Connections	27
Inside the CK Range	8	CK Switch Mechanisms	28
CK Standard Range	10	Accessibility	30
CKA Atronik Range	12	Valve Protection and Diagnostics	31
CKc Centronik Range	16	Technical Data	33
Control Options	20	Approvals	44
Insight 2 – Analysis and Configuration Software	22	Functions	45
Communication Interfaces	23	Client Support and Site Services	46



Comprehensive product range serving multiple industries

Improved efficiency, assured safety and environmental protection.

Rotork products and services are used throughout industry inclusive of Power, Oil & Gas, Water & Wastewater, HVAC, Marine, Mining, Pulp & Paper, Food & Beverage, Pharmaceutical and Chemical industries around the world.

Market leader technical innovator

The recognised market leader for 60 years.

Our customers have relied upon Rotork for innovative solutions to safely manage the flow of liquids, gases and powders.

Global presence local service

Global company with local support.

Manufacturing sites, service centres, sales offices and *Centres of Excellence* throughout the world provide unrivalled customer services and fast delivery.

Corporate social responsibility

A responsible business leads to being the best business.

We are socially, ethically, environmentally responsible and committed to embedding CSR across all our processes and ways of working.

Modular design providing **flexibility and configurability** to suit your application

- › Suitable for inaccessible locations using remote mounted Centronik controls
- › Oil bath lubrication for extended life and mounting in any orientation
- › IP68 8m for 96 hours – double-sealing as standard
- › User friendly commissioning and configuration with non-specialist hand tools
- › Built in redundancy using independent torque and position sensing
- › Fast and efficient maintenance due to plug and socket connections
- › Safe motor-independent handwheel operation available at all times
- › Data extraction for analysis, diagnostics and asset management
- › Local operation, configuration and commissioning up to 100 m from actuator, with remotely mounted Centronik module
- › Backed by Rotork Global Support

The CK actuator range has been designed to meet the needs of diverse actuation applications required by the valve industry and its customers. The modular design concept enables quick product configuration from stock to customer specification with a very short lead time.

The CK range provides the customer with a range of options to suit all of their actuation requirements.

CK actuators are designed for minimum user interaction. Their primary goal is to provide safe and reliable actuation in harsh environments.

The modular CK product range offers simple, robust actuators (CK/CK_R) suited to harsh environments with the option for two different control packages (Atronik and Centronik) to meet exact site requirements. Atronik offers modest control and feedback for a simple integrated starter solution. Centronik offers advanced control and feedback for more complex site system integration and increased flexibility through remote mounting.



CK range



Introduction



Standard isolating duty



Standard regulating / modulating duty



CK isolating duty actuators are designed for on/off valve types that are infrequently operated.

- Shut off valves to isolate the site process
- Safety valves for maintenance activities
- Up to 60 starts per hour at a rate up to 1 start every 6 seconds

CKR modulating duty actuators are designed for positioning valve types that are frequently operated.

- Control valves for fine adjustment of the site process flow
- Optimised fast response drive train
- Up to 1,200 starts per hour

CK Range Universal Design Features

- CK is the solution for users with centralised motor control centres or high temperature and/or sustained vibration applications
- Mechanical or Digital Switch Mechanism (DSM)*
- All major components of CK range actuators are modular
- Hollow output drive to accept rising valve stems
- Plug and socket electrical connection for easier field wiring
- Detachable thrust and non-thrust base options
- Modular construction facilitates:
 - Fast order turnaround and quick delivery
 - Off-the-shelf solution for spares and upgrading
 - Interchangeable motors for different speeds
 - Control package upgrades
 - Indication output changes
- Secure padlockable manual handwheel drive, fully independent of the motor drive train

* DSM only with CKc and CKRc actuators

CK Range Performance Data

- Direct output torque range: 10 - 500 Nm (7 - 369 lbf.ft)
- Max. torque with standard multi-turn gearbox: 6,750 Nm (4,979 lbf.ft)
- Max. torque with standard part-turn gearbox: 205,600 Nm (151,600 lbf.ft)

Introduction

CKA

Atronik isolating duty

CKRA

Atronik regulating / modulating duty



CKC

Centronik isolating duty

CKRC

Centronik regulating / modulating duty



CKA isolating and CKRA modulating duty actuators are equipped with the simple and robust Atronik control module.

- Atronik increases flexibility of options across the CK range
- CK Atronik provides modest integral controls to meet the standard requirements of site specification
- Digital electronic based controls with microprocessor driven easily defined functionality
- Simple control and indication configuration via on board DIP switches
- Integral local control selectors with mode and direction selection
- Simple, user friendly display interface for clear status indication
- Configurable LED colours to suit site standard form
- Optional extra relays for additional remote indication
- Optional analogue proportional control input and output transmitter (4-20 mA)
- Optional local position indicator with mechanically adjustable position
- Basic network bus connectivity
- Isolating duty Class A & B and modulating duty Class C

CKC isolating and CKRC modulating duty actuators are equipped with the intelligent Centronik control module.

- Centronik module can be close coupled or remote mounted up to 100 m from actuator
- CK Centronik provides intelligent integral controls for integration with all types of site control systems
- Remotely mounted Centronik module option facilitates use in harsh environments or restricted space installations
- Microprocessor based controls for functionally sophisticated applications and/or for integration of actuators into fieldbus systems
- Non-intrusive setting of Centronik module via local control knobs, infrared or optional *Bluetooth*[®] wireless communication
- Multilingual user interface
- Fully configurable LCD display
- Optional analogue control input and Current Position Transmitter (CPT) 0-20 and 4-20 mA
- Optional Current Torque Transmitter (CTT) 0-20 and 4-20 mA with Digital Switch Mechanism (DSM) only
- Constant valve position monitoring with DSM even during power loss
- Network bus connectivity
- Datalogging and analysis with Insight 2 software
- Isolating duty Class A & B and modulating duty Class C

Inside the CK Range

Components of the modular CK actuator design

1 Atronik module



The Atronik control module provides the user with simple, robust valve control and clear valve status indication.

- 1a LED status indication display plus non-intrusive local controls
- 1b Plug and Socket connection
- 1c Double-sealing water and dust ingress protection

2 Centronik module



The Centronik control module provides the user with comprehensive intelligent valve control, detailed data logging and asset management.

- 2a Multilingual display plus non-intrusive local controls
- 2b Plug and Socket connection
- 2c Double-sealing water and dust ingress protection
- 2d Up to two extra option cards

Module Compatibility Chart

Symbol	Actuator
	CK & CKR - no control module
	CKA & CKRA - Atronik control module
	CKc & CKRc - Centronik control module

3 Standardised motor module



Motor modules utilise the same connection method across all speeds for each size CK.

4 Manual handwheel



Independent manual override for emergency operation.

5 Double-sealing water and dust ingress protection



Proven double sealing arrangement to maintain IP68 (8m for 96 hours) protection.

6 Mechanical switch mechanism (MSM)



Cam engaged position and torque switches with reduction gearing for extended travel.

7 Digital switch mechanism (DSM)



Absolute encoder device for fully digital position and torque measurement.

8 Additional Indication Drive



Increases functionality beyond the switch mechanism to include local position indication, intermediate switches, potentiometer or loop powered 4-20 mA CPT.

9 Local indication cover



Rotate through 360° in 90° increments to suit installation in any orientation.

10 Detachable thrust bases



Separate the base from the actuator for faster maintenance.

11 Rotork Bluetooth® Setting Tool Pro



View, adjust and extract data from Centronik control modules.

Inside the CK Range

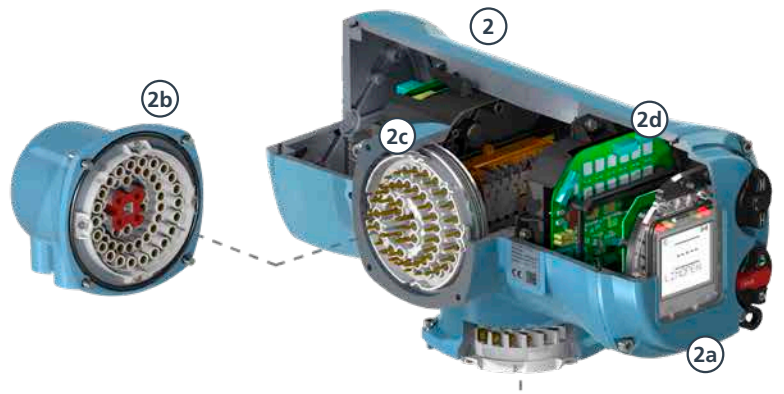
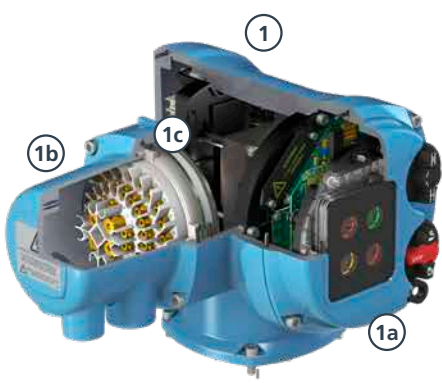

CK range

Modular Actuator Design

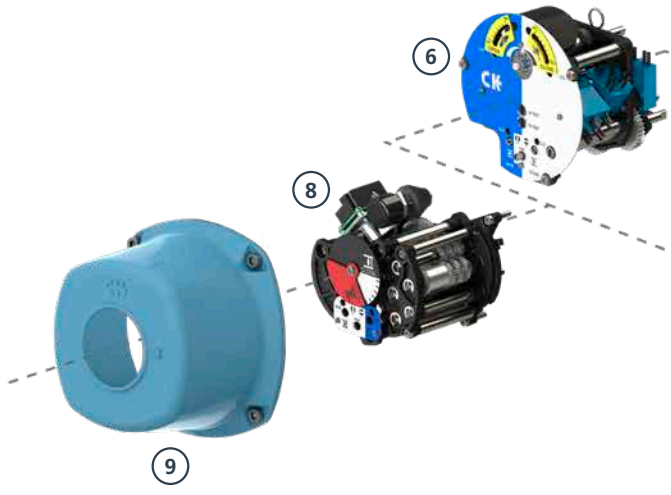
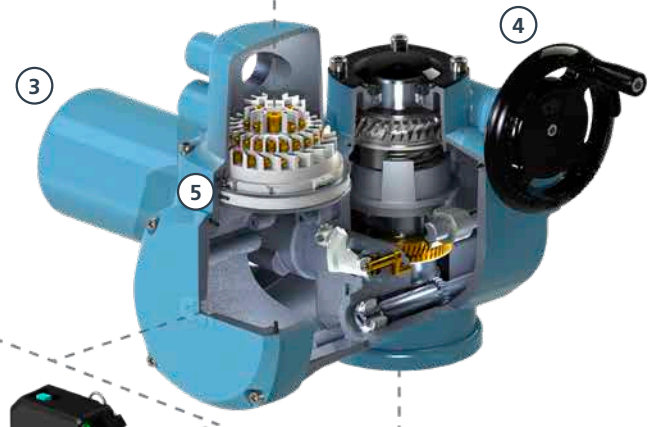

CK Standard Range

The multi-turn Rotork CK and CKR actuators are the simplest models in the CK range. They are designed for use with external controls and motor switchgear.

CK actuators comprise the following components:

- Motor, drive train and independently declutchable manual override handwheel for hand operation including padlockable hand/auto lever
- Standard valve flange mounting including removable drive nut for machining to match the valve stem
- Electric plug and socket connection for power and control wiring
- Drive train permanently immersed in an oil bath to ensure maximum efficiency and avoid the damaging tunneling effects associated with grease filled actuators.

To operate a CK or CKR, external controls with motor switchgear must be wired to the applicable actuator terminals. The wiring diagram and terminal plan will detail electrical connection requirements for operation.

A CK or CKR actuator can be upgraded with an Atronik or Centronik control module to provide a ready-to-operate actuation solution with integral controls and motor switchgear.

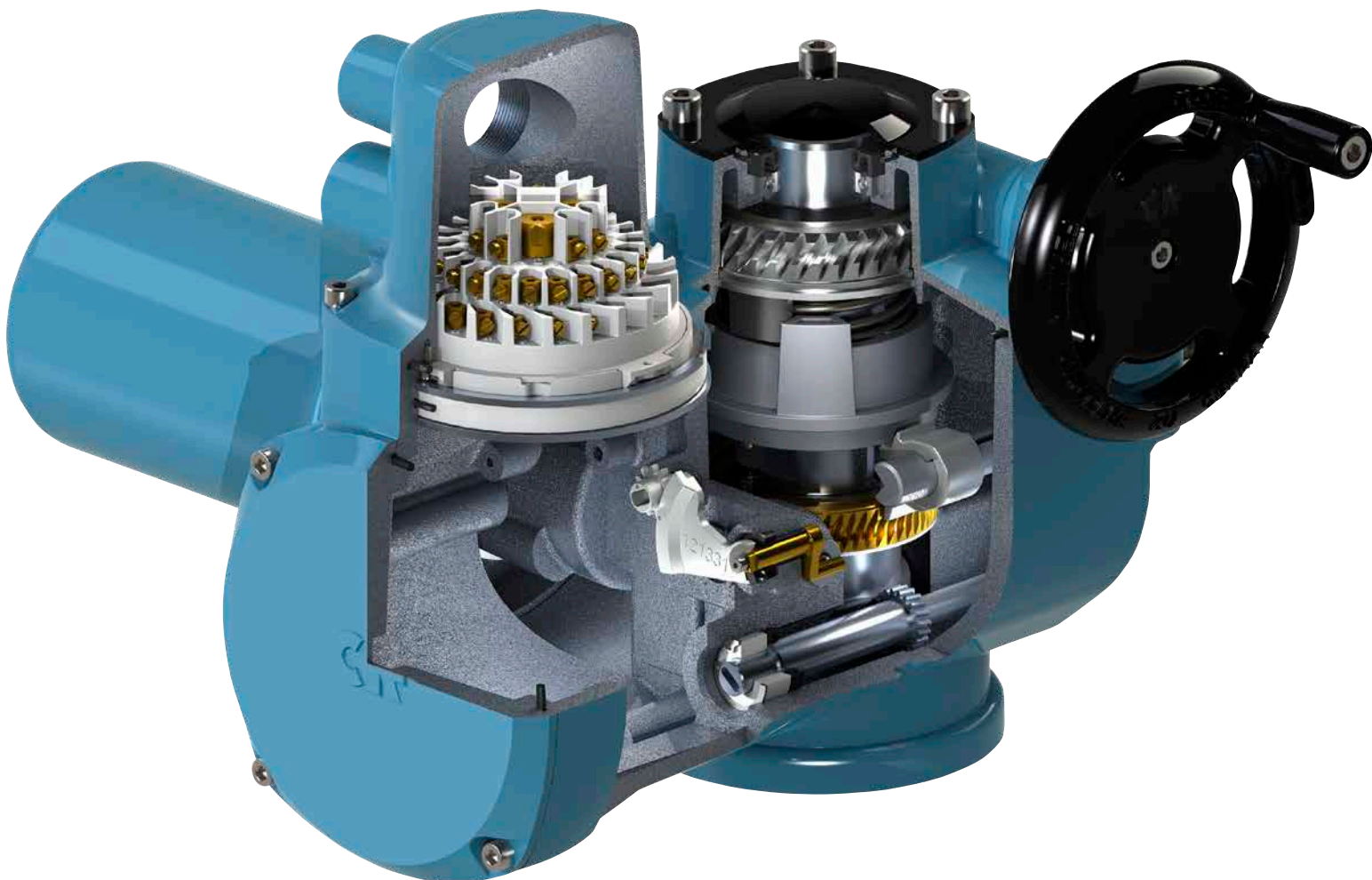

CK Standard Range

Motor

To meet the specific torque characteristics of the wide variety of applications in our global market, Rotork has developed a full range of motors with high starting torque. Special features have been designed into the drive train to ensure uninterrupted operation even when the valve or damper torque demand increases due to wear or requirement for maintenance. For isolating service applications this includes a hammer blow mechanism within the drive train to provide an impact force on motor start.

To avoid damage to the actuator motor, thermal protection is included as standard using a thermo switch embedded in the motor windings. This will inhibit actuator operation if the ambient temperature of the motor exceeds specification.

Should the motor require replacement, quick fit electrical connections and mechanical fittings reduce the service down time required.

Actuator switch mechanism

The purpose of the actuator switch mechanism is to sense valve position and torque so the actuator controls can control the motor. Depending on the application, it will seat at the ends of travel either on torque or position. Therefore it is also vital that end travel torque and position limits are adjustable to suit the particular application requirements.

CK and CKR actuators are compatible with the Mechanical Switch Mechanism (MSM). Instantaneous position and torque are sensed mechanically and IP67 rated micro switches provide end of travel indication as well as torque trip indication. Torque and position switches for both directions require mechanical configuration.

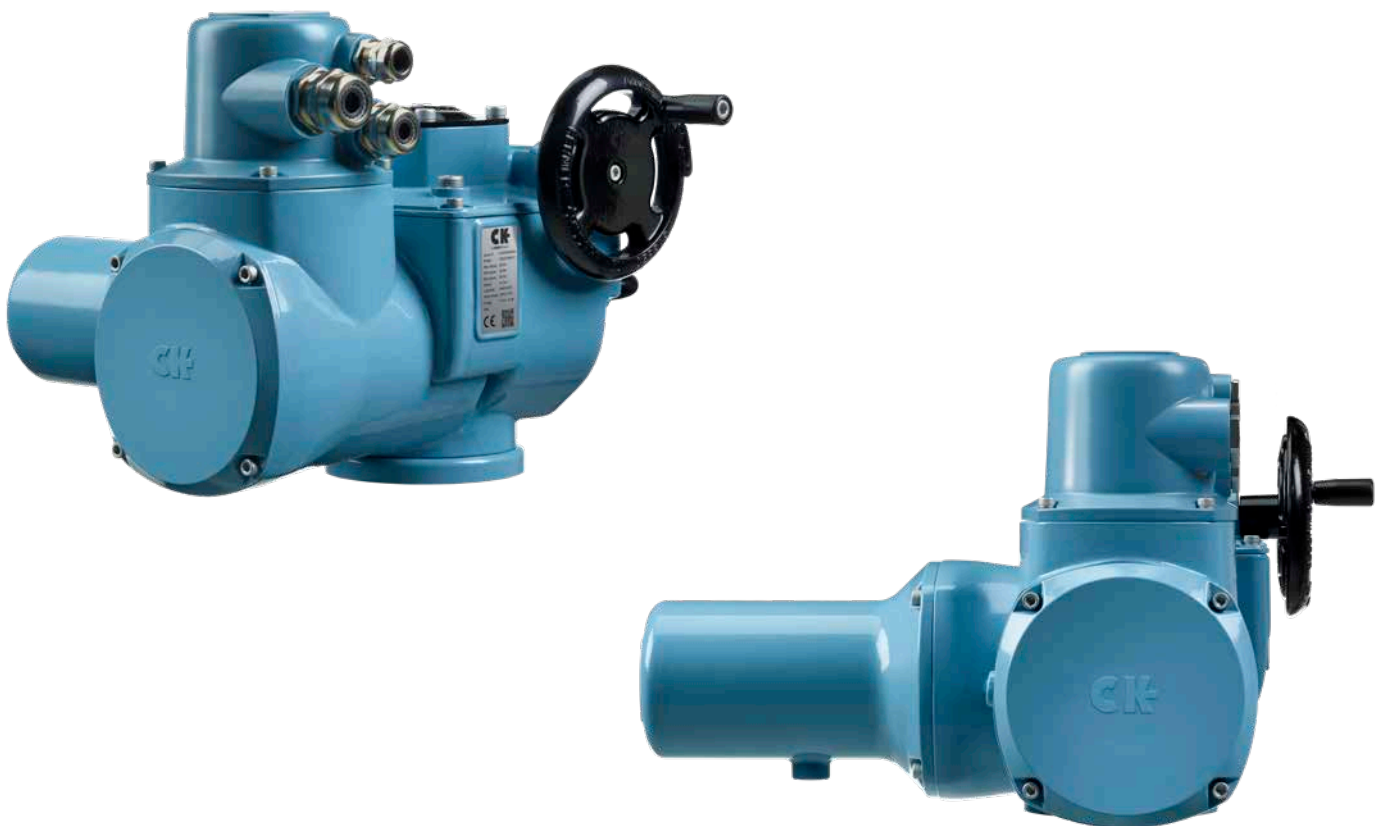

CKA Atronik Range

The close coupled Atronik control module comprises simple electronic controls with a visual user interface for status and fault information.

Rotork CKA and CKRA actuators provide reliable valve automation with built in control protection.

Motor switchgear

For CKA and CKRA units, the motor switching is controlled with a reversing contactor. This enables integrated directional control for isolating duty applications and proven reliability for soft modulating duty applications.

Integral controls

CKA and CKRA actuators are offered as a ready-to-operate actuation solution. The motor switch gear, power supply components and integral control logic interface allow a unit to be operated with the local controls when applying only an adequate power supply. Remote operation can be achieved using appropriate commands to the pre-defined terminals. Electrical mating between the Atronik module and CK actuator uses a plug & socket connection matching the terminal housing connector.

Status Indication

Atronik controls offer built in fault detection with clear local LED indication. Two standard configurable relays are included to provide remote indication for position or torque limit, motor stall, thermostat trip, mode selection, ESD active, blinker moving status and manual override operation.

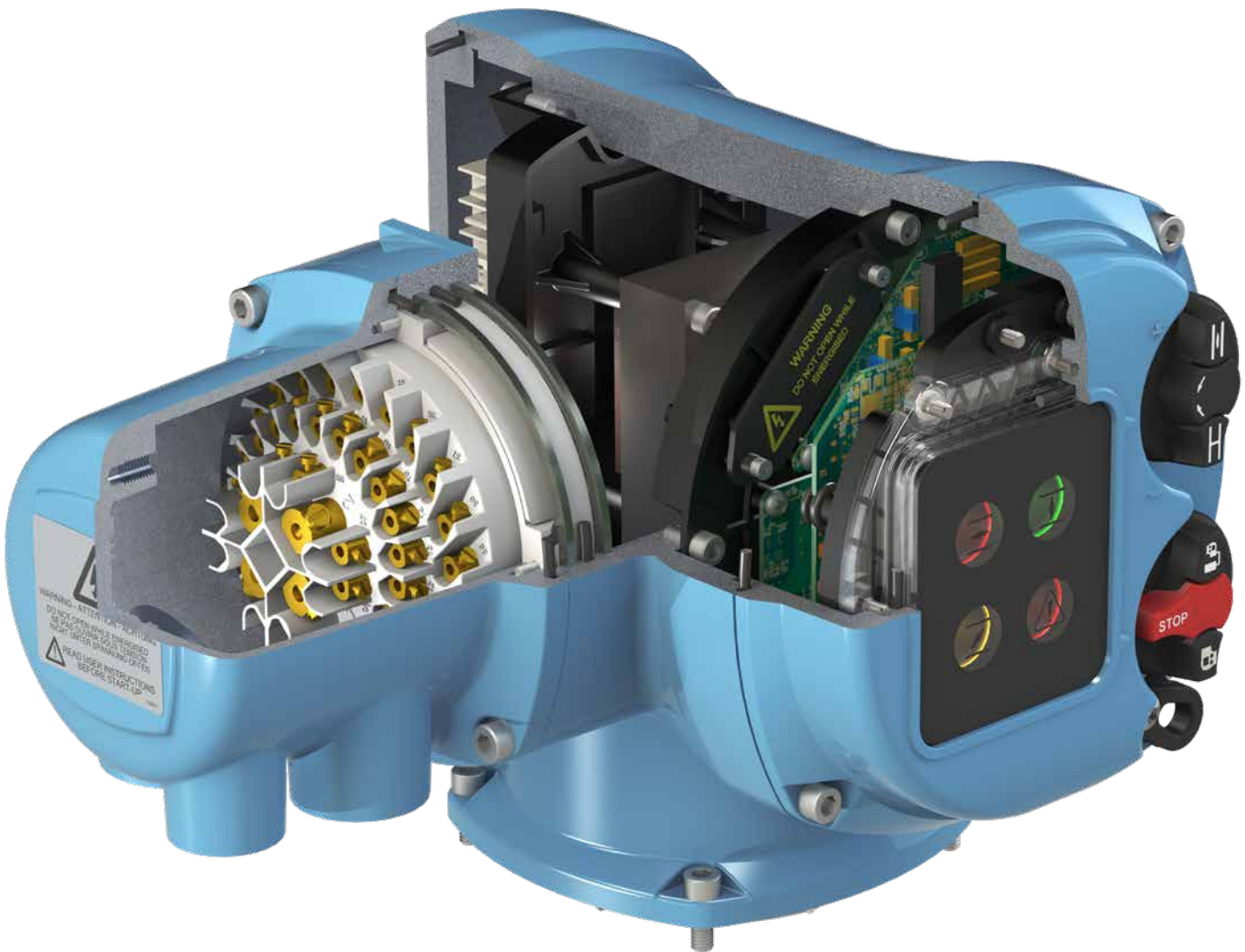

CKA Atronik Range

Electrical plug & socket connection

The Rotork plug & socket connection utilises a uniform fitment between electrical modules. This maintains the terminal pin allocations for the various actuator functions.

A plug & socket connection is used between a CK (or CKR) and the terminal housing to provide a quick disconnect method for maintenance work. This solution also prevents the field wiring connections being disturbed.

For Atronik actuators, a plug & socket connection is also used between the CK or CKR and Atronik control module. This enables quick removal and connection of the actuator controls during maintenance periods. The terminal housing plugs into the Atronik module in the same manner as a CK or CKR actuator.

Actuator switch mechanism

CKA and CKRA actuators are compatible with the Mechanical Switch Mechanism (MSM).

Instantaneous position and torque are sensed mechanically and IP67 rated micro switches provide end of travel indication as well as torque trip indication. Torque and position switches for both directions require mechanical configuration.

Optional extras

To further extend functionality of Atronik equipped actuators, additional option cards can be fitted to the internal electronics. Analogue control (4-20 mA, 0-5 V or 0-10 V) and feedback (4-20 mA) is available for positioning applications. Four extra configurable relays offer additional feedback contacts.



CKA Atronik Range

Operating control mode

The Open/Close and Local/Stop/Remote selectors are magnetically coupled to the designated switches with no physical penetration through the control cover. This further enhances the environmental protection of the CK actuator range. The Local/Stop/Remote selector defines the current actuator operating mode and is lockable in any position.

Local will provide operation via the open/close selector. Stop will prevent all actuator electrical operation. Remote will prevent local electrical operation of the actuator; operation is only viable through the hardwired digital inputs, analogue control source or network option card.

Automatic self-test diagnostics

Actuator conditions are monitored throughout operation to ensure reliable actuation. Should an alarm condition occur, the fault condition LED will illuminate which will prompt the operator to investigate.

Simple configuration

Control module functions are determined by DIP switch settings. The DIP switches are positioned behind the user interface and located on the exposed electronics for easy access.



Atronik CK actuator with Additional Indication Drive (AID)

CKA Atronik Range

Modern actuators can be adapted to a wide variety of special applications. Monitoring and diagnostic functions are an increasingly important requirement for valve automation.

Functionality of the Atronik module will vary depending on additional option cards fitted for network and analogue systems.

Atronik compatible CK and CKR actuators will only report actuator movement, position limit and torque limit status from the mechanical switch mechanism. If the optional potentiometer drive is fitted, intermediate position feedback can be communicated to the Atronik for options that use intermediate position.

Indication LEDs

The Atronik control module includes four status indicators for position and fault indication. When a condition is active, the applicable LED will illuminate. For position feedback, open and close limit status is indicated with configurable red or green LEDs and intermediate position is indicated with a yellow LED behind the relevant position indicator. If a fault condition occurs, fault is indicated with a red LED behind the fault indicator.



OPEN
position status



CLOSE
position status



INTERMEDIATE
position status



FAULT
status



CKc Centronik Range

The close coupled or remote mounted Centronik control module comprises intelligent electronic controls with a visual user interface for setting configuration.

When the Centronik is fitted in combination with the digital switch mechanism, all position and torque settings can be adjusted non-intrusively via the display screen. If the optional Bluetooth wireless module is included in the Centronik then configuration can be performed wirelessly with the Rotork Setting Tool or through Insight 2 PC software.

Centronik actuators (CKc and CKrc) perfectly suit site locations where complex system integration is required. When applicable, actuator configuration can be performed over the network interface. The communication options also support site asset management attributes for detailed identification and logging purposes.

Remotely mounted electronics

Rotork provide an option to remotely mount the Centronik module of a CKc or CKrc actuator. A cable length of up to 100 m (328 ft) enables sufficient access to Centronik equipped actuators where the valve or damper location is restricted by site space constraints.

Integral controls

Actuators equipped with the Centronik module (CKc or CKrc) are offered as a ready-to-operate actuation solution. The motor switch gear, power supply components and integral control logic interface allow a unit to be operated with the local controls when applying only an adequate power supply. Remote operation can be achieved using appropriate commands to the pre-defined terminals. Electrical mating between the Centronik module and CK actuator uses a plug & socket connection matching the terminal housing connector.

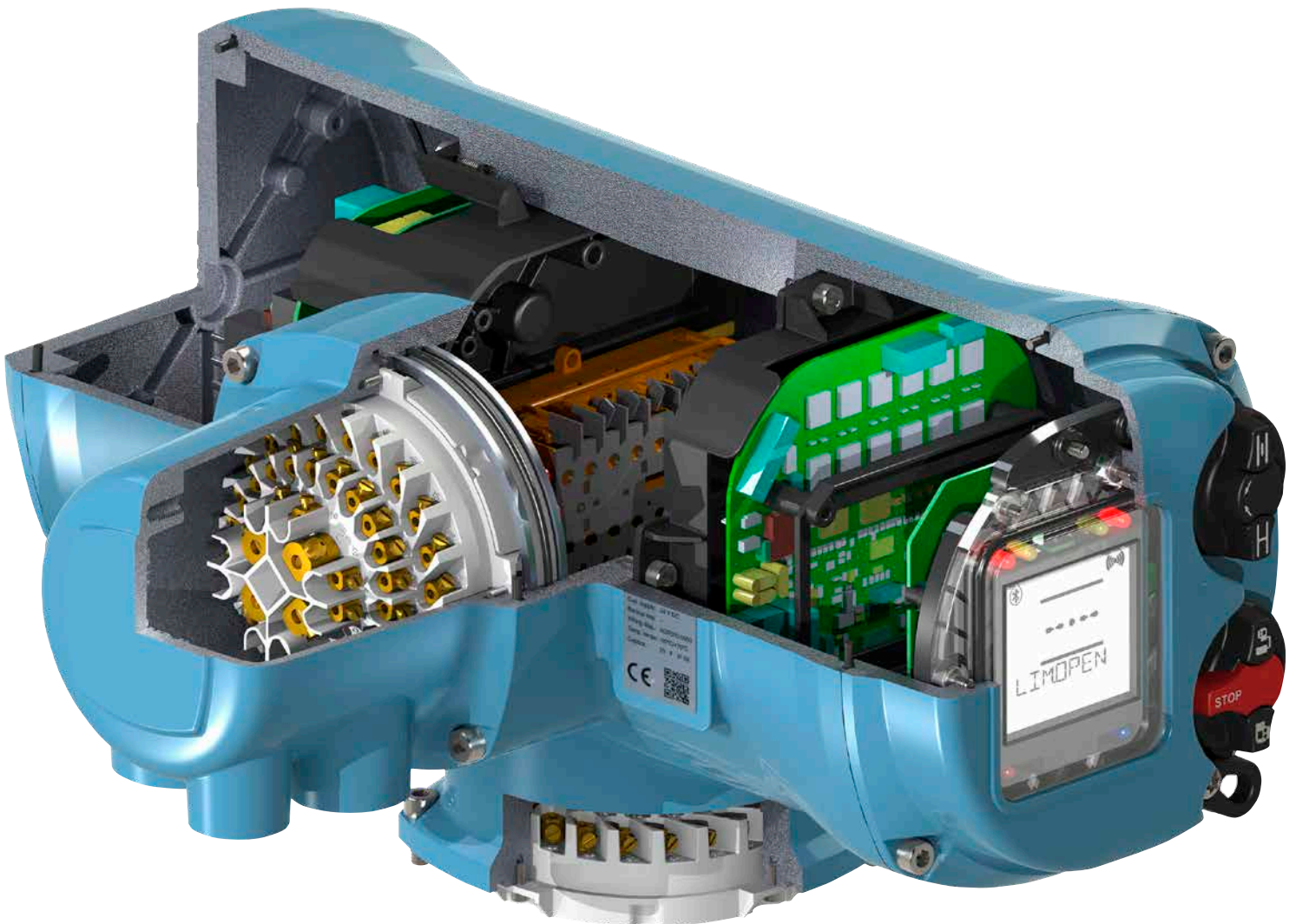

CKc Centronik Range

Electrical plug & socket connection

The Rotork plug & socket connection utilises a uniform fitment between electrical modules. This maintains the terminal pin allocations for the various actuator functions.

A plug & socket connection is used between a CK or CKR and the terminal housing to provide a quick disconnect method for maintenance work. This solution also prevents the field wiring connections being disturbed.

For Centronik actuators, a plug & socket connection is also used between the CK or CKR and Centronik control module. This enables quick removal and connection of the actuator controls during maintenance periods. The terminal housing plugs into the Centronik pack in the same manner as a CK or CKR actuator.

Actuator switch mechanism

CKc and CKRc actuators are compatible with the Mechanical Switch Mechanism (MSM) and the Digital Switch Mechanism (DSM).

MSM – Instantaneous position and torque are sensed mechanically and IP67 rated micro switches provide end of travel indication as well as torque trip indication. Torque and position switches for both directions require mechanical configuration.

DSM – Position and torque is measured by Hall effect sensor absolute encoder technology. Intermediate position and torque values are transmitted to the control module for further processing. Torque and position limit values are configured non-intrusively in the control module software.

Diagnostics

The intelligent Centronik module has the ability to log specific data sets that are particularly relevant to actuator operation. Attributes such as actuator build and serial number are stored as static information; while active attributes such as Open/Close operations, Open/Close limit switch trips, Open/Close torque trips, motor starts and number of actuator power cycles are collected over the lifetime of the actuator. These provide a log of actuator activity that can be used for process analysis and preventative maintenance scheduling.

Auto limit setting

In certain applications it is useful to have an automatic limit setting function. This uses hard stops in the valve to sense the correct position limits. CK actuators equipped with the digital switch mechanism are able to perform an automatic setting process that spans the complete valve stroke. Movement continues in both directions in turn until 40% torque is measured. Once the operation is complete in both directions, the positions limits are calibrated at the measured end of travel points and the actuator is commissioned with the valve.

Motor switchgear

For CKc units, the motor switching is controlled with a reversing contactor. This enables integrated directional control for isolating duty applications. For modulating duty applications that require a higher duty cycle we offer the CKRc actuator with an integral solid state starter. Please contact Rotork to determine which option best suits your application.



 Bluetooth®

CKc Centronik Range

Operating control mode

The Open/Close and Local/Stop/Remote selectors are magnetically coupled to the designated switches with no physical penetration through the control cover. This further enhances the environmental protection of the CK actuator range. The Local/Stop/Remote selector knob defines the current actuator operating mode and is lockable in any position.

Local will provide operation via the open/close selector knob and allow configuration changes. Stop will prevent all actuator operation unless an ESD command is set to override a local stop condition. Remote will prevent any local operation of the actuator or modification of the setting configuration; operation is only viable through the hardwired digital inputs, analogue control source or network option card.

Valve and damper position indication

In addition to the local indication LEDs, the graphical display will show the current position in large seven segment characters. If a mechanical switch mechanism is fitted then it must be equipped with the optional potentiometer to report position to the Centronik module.

Control commands

Operating control commands such as intermediate analogue position and digital open/close signals can be displayed locally on the actuator to ensure correct communication with the DCS.

Automatic self-test diagnostics

Actuator conditions are monitored throughout operation to ensure reliable actuation. Should an alarm condition occur, the graphical display will provide an alarm status description on screen that will offer the site operator a start point to continue fault finding. Alarm conditions can also be separated into the NAMUR categories to suit system integration.

Main settings menu

The main menu provides the user with an intuitive logical structure for all actuator configuration settings.

Non-intrusive configuration

Provided the unit is fitted with a digital switch mechanism, the end of travel position limits and torque trip limits can be set via the Centronik user interface display and local open/close selector.

The Rotork Setting Tool will enable setting modification using infrared or Bluetooth wireless communication. For units fitted with the mechanical switch mechanism, position and torque limits require manual calibration.

Remotely mounted starters

Rotork provide an option to remotely mount the Centronik module of a CKc or CKRC. A cable length of up to 100 m (328 ft) enables sufficient access to Centronik equipped actuators where the valve or damper location is restricted by site space constraints.



Remote mounted Centronik controls

CKc Centronik Range

Modern actuators can be adapted to a wide variety of special applications. Monitoring and diagnostic functions generate signals and collect operating feedback data.

For actuators with the optional Centronik module, accessing detailed operating data is performed via the clearly structured and intuitive multilingual user interface. Functionality of the Centronik module will vary depending on additional option cards fitted (for network and analogue systems) and the type of actuator switch mechanism fitted.

The mechanical switch mechanism will only report actuator movement, position limit and torque limit information. If an optional potentiometer drive is fitted, intermediate position feedback can be communicated to the Centronik display. Configuration of the actuator limits will require manual setup.

The digital switch mechanism can report all position and torque information to the Centronik module for data logging and operator feedback. Configuration of actuator limits can be performed through the non-intrusive display interface with a Rotork Setting Tool or via Insight 2 PC software package if the optional Bluetooth wireless module is fitted.

Password protection

The Centronik module incorporates a password protection system to prevent unauthorised access to actuator setting modification. This is an important part of maintaining the operating site's security integrity.

Bluetooth wireless security

For Centronik modules that include optional Bluetooth wireless technology, communication is performed via secure infrared initiation with the Rotork Setting Tool or through a Bluetooth wireless enabled PC running Insight 2 PC software. Every CKc or CKrc is immune to connection by non-Rotork devices or programmes and a valid password entry is required to edit any actuator configuration settings.

Backlit display

The multilingual user interface display on the Centronik module shows text and numerical figures relevant to actuator operation. Graphical symbols are also visible for appropriate functions. The display backlight is designed to provide good visibility in direct sunlight or challenging weather conditions.

Indication LEDs

The Centronik display incorporates indication LEDs that can show position, torque, alarm status and connection activity. For position feedback; open and closed limit indication is user configurable (red or green) and intermediate position is yellow. It is important that operations and maintenance personnel can safely work around the actuated valve and know its status at all times. Duplicated LEDs facilitate wider viewing angle. Alarm status will trigger a solid red LED at any point of travel. An active Bluetooth wireless connection will be indicated as a solid blue LED.

Position display



Non-Intrusive setting



Asset management



Actuator error



Control Options

Rotork actuators are designed to be integrated within any automation system or application around the world. CK range actuators are compatible with full external controls or more complex control systems with the Atronik or Centronik control module.

External controls (CK & CKr)

The term “external controls” refers to the controls associated with standard actuators without integral controls or motor switchgear. Only a few components are housed in the actuator enclosure to provide feedback and connectivity to the external controls.

External controls will commonly be housed in a control cabinet with a controlling system such as a PLC for actuator operation. This external controller provides the logic that oversees control and feedback signals, including motor operation in the open and closed direction, limit switch status, torque switch status, motor protection and intermediate position (if applicable). External motor control switchgear will normally be located in the plant’s motor control centre. Care and attention must be paid during the wiring and programming stages to ensure the control system operates the valve or damper in the correct direction. Should local control for plant operation use be required, additional hardware must be installed and incorporated into the external controller programming appropriately.

Actuators that require external controls within the Rotork CK range are designated as CK for isolating duty and CKr for modulating duty.



Control Options

Atronik (CKA & CKRA)

The addition of the Atronik module to the CK provides reliable, integral control for use with most site control systems. It permits the use of hardwired, analogue or basic network control and indication.

Atronik equipped actuators allow the valve maker/integrator the ability to pre-test the motorised valve assembly using local control with no extra wiring or motor control gear required.

Atronik configuration is achieved by intrusive adjustment of the DIP switches. Optional extras utilise configuration by DIP switches in a similar manner to the standard control and feedback features.

Actuators that include the integral Atronik control module are designated CKA for isolating duty and CKRA for modulating duty.



Centronik (CKc & CKRc)

The addition of the Centronik module to the CK provides intelligent, integral control for use with all site control systems. It permits the use of hardwired, network or analogue control & indication, offering cost-effective implementation with centralised control systems.

Centronik actuators allow the valve maker/integrator the ability to pre-test the motorised valve assembly using local control with no extra wiring or motor control gear required.

Configuring an actuator fitted with Centronik is easy and non-intrusive. A password protected setup menu is visible on the Centronik display. Standard navigation through the menu driven configuration screens is carried out using the local open/close selector. Settings can also be adjusted with a Rotork Setting Tool via infrared or optional Bluetooth wireless communication. The Centronik display also provides position indication, status and alarms for operation. Centronik includes data logging capabilities showing actuator starts, status and events on screen.

Actuators that include the integral Centronik control module are designated CKc for isolating duty and CKRc for modulating duty.



Insight 2 – Analysis and Configuration Software

For actuators with close coupled or remote mounted Centronik control, all settings can be directly performed at the actuator using the local control knobs and Rotork Setting Tool. If the actuator is equipped with the optional Bluetooth wireless communication module, settings can be adjusted using a device equipped with Rotork's Insight 2 PC software.

The extensive Insight 2 PC software package can be used on any CKc actuator equipped with Bluetooth wireless technology. It enables the operator to view the actuator configuration and data log files for review and modification purposes. If carrying a PC to the actuator in the plant is not desirable then a Rotork Setting Tool can be used to transfer actuator attributes to Insight 2 from any CKc or CKRc actuator.

Rotork Insight 2 PC software

Actuator configurations and data log information can be saved locally on any PC that has Insight 2 PC software installed. This data will ensure replacement modules can be quickly configured with the original actuator settings.

Rotork Insight 2 diagnostics

Insight 2 PC package is the ideal tool to view and save the Centronik data log. This provides site plant operators with useful data to evaluate process characteristics and valve wear trends.

Bluetooth connection

Connection between the actuator and programming device is based on standard Bluetooth wireless communication protocol, supported by most laptops and PDAs. The connection is password protected to exclude any unauthorised access.

The addressed actuator indicates access via a blue indication LED visible on the actuator display. The actuator can be clearly identified on Insight 2 by its unique serial number and user defined Bluetooth wireless ID tag.

Insight 2 PC software functions

- Programming the operation settings of CKc or CKRc actuators
- Reading all current configuration settings
- Viewing the data log file of the connected actuator
- Various live actuator operations
- Saving data log and configuration data for future use
- Loading new configuration data into a CKc or CKRc.

For more information on Insight 2 and the Rotork Bluetooth® Setting Tool *Pro* please refer to PUB095-001.



Communication Interfaces

The CK range is designed to accommodate all system integration requirements. The modular design approach offers various levels of actuator intelligence within the CK range.

A CK without integral controls would be suitable for a simple external hardwired control system. CKA actuators provide an integral starter with simple status indication. CKc actuators provide a fully intelligent solution for complex autonomous site control.



Atronik Inputs

Standard:

- Four galvanic isolated command inputs. Open, Close, Stop/Maintain and ESD.

Optional:

- Analogue input for positioning. 4-20 mA / 0-5 V / 0-10 V loop configuration.

Atronik Outputs

Standard:

- One galvanic isolated, volt-free change over contact for availability/fault indication.
- Two galvanic isolated, volt-free relay contacts. Configurable functions and normally open (N/O) contact form.

Optional:

- Four additional galvanic isolated, volt-free relay contacts. Configurable functions and normally open (N/O) contact form.
- Analogue position output. 4-20 mA loop configuration. Signal inversion possible (Close limit position = low or high signal).

Ever changing site requirements and actuator functions have been considered with the CK range. CK actuators can always be upgraded to include Atronik or Centronik controls for improved system capabilities and DCS integration.

Hardwired digital control to the DCS

Atronik and Centronik control modules have the facility to accommodate a number of hardwired inputs and outputs for actuator control and feedback. Specific functions and terminal allocations are detailed on the actuator wiring diagram and terminal plan.



Centronik Inputs

Standard:

- Six galvanic isolated command inputs. Open, Close, Stop/Maintain, ESD, Open Interlock and Close Interlock.

Optional:

- Analogue input for positioning. 4-20 mA, 0-5 V, 0-10 V or 0-20 V loop configuration.

Centronik Outputs

Standard:

- One galvanic isolated, volt-free change over contact for availability/fault indication.
- Four galvanic isolated, volt-free relay contacts. Configurable function and contact form (N/O or N/C).

Optional:

- Eight additional galvanic isolated, volt-free relay contacts. Configurable function and contact form (N/O or N/C).
- Analogue position output. 0-20 or 4-20 mA loop configuration. Signal inversion possible (Close limit position = low or high signal).
- Analogue torque output. 0-20 or 4-20 mA loop configuration.

All optional equipment can be fitted to accompany or replace standard control and feedback solutions.

Communication Interfaces

Modern facilities require seamless control and feedback from the actuator to the control room plus asset management data. Plant managers need operational data in real time. Process operators need full control of their facilities at all times. Maintenance managers need asset management data so that they can plan maintenance outages efficiently.

To meet these requirements, digital communication networks allow electric actuators and other field devices to be controlled and monitored by computer. Using a fieldbus network reduces the requirement for extensive site wiring and purpose built hardware.

Rotork actuators are network compatible when you select the Atronik or Centronik control modules. Field upgrades for CK and CKR actuators allow integration into existing site network systems.

Serial communication

Rotork has developed the Atronik and Centronik control modules with consideration to the continuous development of industrial network systems. With a dedicated systems support team, Rotork can engineer new functionality for compatible fieldbus networks that relate specifically to valve actuation.

All fieldbus communication options for the CK range are fully upgradable to suit future firmware releases, which enable extended functionality.

Fieldbus communication can be used independently or in conjunction with digital hardwired control systems depending on the specific application or site requirements.

Pakscan™

**PROFI
BUS**

DeviceNet®
CONFORMANCE TESTED

FOUNDATION

Modbus®

HART
COMMUNICATION PROTOCOL

PLC/DCS

CKRC Field Unit

CKRA Field Unit



Communication Interfaces

Modbus®

Modbus modules suitable for single or dual communication highways may be included in CKc or CKRc actuators and provide Fieldbus communication of all the actuator control functions and feedback data. Data is carried on an RS485 data highway and the communications protocol used is Modbus RTU. System variables such as unit address and data baud rate are programmed over the infrared or Bluetooth wireless communication data link. For more information please contact Rotork.

DeviceNet®

DeviceNet® is a communications protocol which utilises the CAN bus network. The CK DeviceNet® module Electronic Data Sheet (EDS) file is used to set up the actuator parameters and allow system performance to be optimised. Status, alarms and control functions are available over the DeviceNet® network. For more information please contact Rotork.

Foundation Fieldbus®

An IEC 61158-2 compliant Foundation interface module allows the actuator to be connected to a Foundation network. The device has link scheduler capability as well as digital and analogue function block capability. Foundation Fieldbus actuators can communicate directly between themselves without the need for a host supervisory system. For more information please contact Rotork.

Pakscan™

An internally mounted *Pakscan* field unit is available for remote control and status indication over a fault tolerant two wire serial link. System variables programmable over the Bluetooth data link. For more information please contact Rotork.

Profibus®

A Profibus DP interface module is available to integrate CKc and CKRc actuators into a Profibus network. Full compatibility with EN 50170 is provided and the Profibus network allows full actuator control and feedback of data to the host. For more information please contact Rotork.

HART®

Highway Addressable Remote Transducer (HART) is a process control communication protocol. The signal consists of two parts, the analogue 4-20 mA current loop and a superimposed digital signal. Traditionally the 4-20 mA loop is used for control and the superimposed digital signal for feedback, diagnostics and configuration. Configuration and feedback using the HART digital signal can be achieved using the host connected to the actuator to select the parameters required. The majority of user configurable settings can be made over the HART communication protocol. For more information please contact Rotork.

Profinet and Modbus TCP

Industrial Ethernet solutions are fast becoming a popular choice for industrial automation. Rotork has developed a solution that allows a Modbus TCP or Profinet connection to CK range actuators.

For more information on these solutions, refer to PUB002-116.

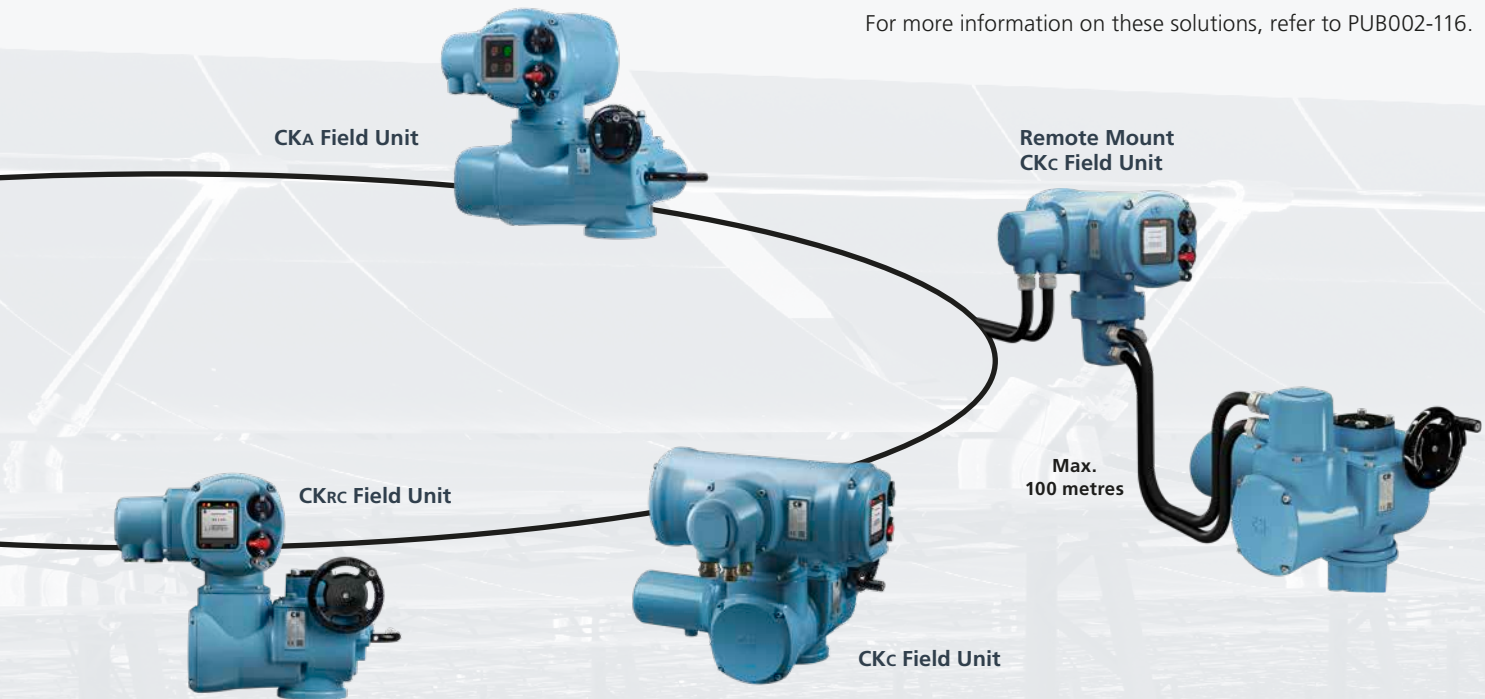

Electrical Connections

Modular electrical connections

Plug & socket connections have been designed to work efficiently and effectively within the modular design approach for the CK range. All plug & socket connections are universal within the CK range and remain uniform between CK, CKA and CKc actuator types. For further details on the plug & socket connection please refer to the actuator terminal plan.

Terminal housing

The terminal housing module for the CK range includes one plug & socket connection with separate power and control field wiring terminals. Three conduit entries are provided as standard to suit various gland/cable size requirements. Please refer to the technical data section of this brochure for further details.

Additional conduit entries

Alternative socket housings are available with up to six conduit entries. Blank housings can be supplied to meet bespoke conduit entry requirements.

Plug & socket sealing

All plug & socket connections include robust double sealed protection. The IP68 rating is maintained whilst the terminal housing or control module is unmated.

Disconnect module

For Atronik and Centronik network options, a larger disconnect module can be supplied as a substitute for the standard terminal housing. The disconnect module ensures that network loops remain complete whilst the module is disconnected from the actuator. This facilitates continued operation of the network loop during maintenance activities.

Temporary environmental protection

During maintenance activities, the terminal housing plug may be disconnected from the actuator or control socket. An optional parking housing can be supplied that enables the loose plug to be fixed in place to prevent physical or environmental damage (water ingress) to the terminal pins. The parking housing includes fixing points to wall mount the unit and the inclusive parking cover can be used to protect the exposed socket on the actuator during transport.



Double O-ring sealed modular plug and socket connections

Mechanical Connections

Reliable valve interfacing

All CK range mounting flange dimensions are in compliance with ISO 5210 or MSS SP-102. Please refer to the technical data section of this brochure for further details.

Output drive couplings

All CK range actuators have a **B1** (bore & key) output drive type as standard. **B3** (bore & key) and **B4** (blank) are available through the use of adapter sleeves designed to insert into the standard B1 output.

Thrust bearing coupling

A detachable thrust base can be fitted for thrust bearing applications. The **A** type drive assembly is supplied as a self-contained cartridge assembly, facilitating quick removal and reassembly. Please refer to the technical data section of this brochure for details of maximum axial thrust ratings.

Non-thrust – 'B' type coupling

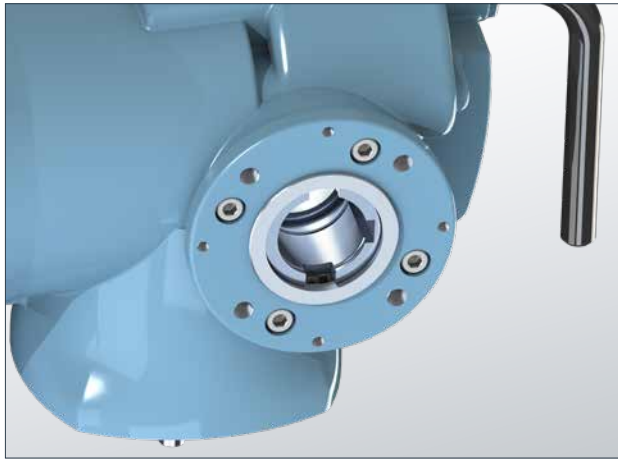

B1 base view



B1 to B3 adaptor



B1 to B4 adaptor



B1 base view with B3 adaptor



B1 base view with B4 adaptor

Thrust – 'A' type coupling



Thrust base: exploded view

CK Switch Mechanisms

Mechanical Switch Mechanism (MSM)

The MSM instantaneously senses position and torque mechanically and IP67 rated micro switches provide end of travel indication as well as torque trip indication. Torque and position switches for both directions require mechanical configuration.

Setting of position and torque limits

After removal of the switch mechanism cover, limit and torque settings are easily accessed and adjusted using a flat pan screwdriver. For units fitted with the additional indication drive, the indication mechanism includes holes to access the switch mechanism interface.

Reduction gearing

The reduction gear module, within the mechanical switch mechanism, can be adjusted to suit the required output turns for full valve travel. The standard reduction gearing can accommodate application requirements of up to 1,500 turns.

Blinker contact for movement indication

A blinker contact is fitted to the mechanical switch mechanism to provide movement indication throughout valve travel. The blinker contact is separate to other micro switches.

Heater

The resistive heater maintains a stable and humidity free environment for the internal switch mechanism compartment of the CK actuator. The heater utilises an independent power supply to ensure the integrity of the switch mechanism is maintained during a mains power loss.

Indication and control switches

Four switches are present as standard, two for end of travel position indication and two for torque trip indication in each direction. Two additional position limit switches and two additional torque switches are available for applications that require dual potential switching.

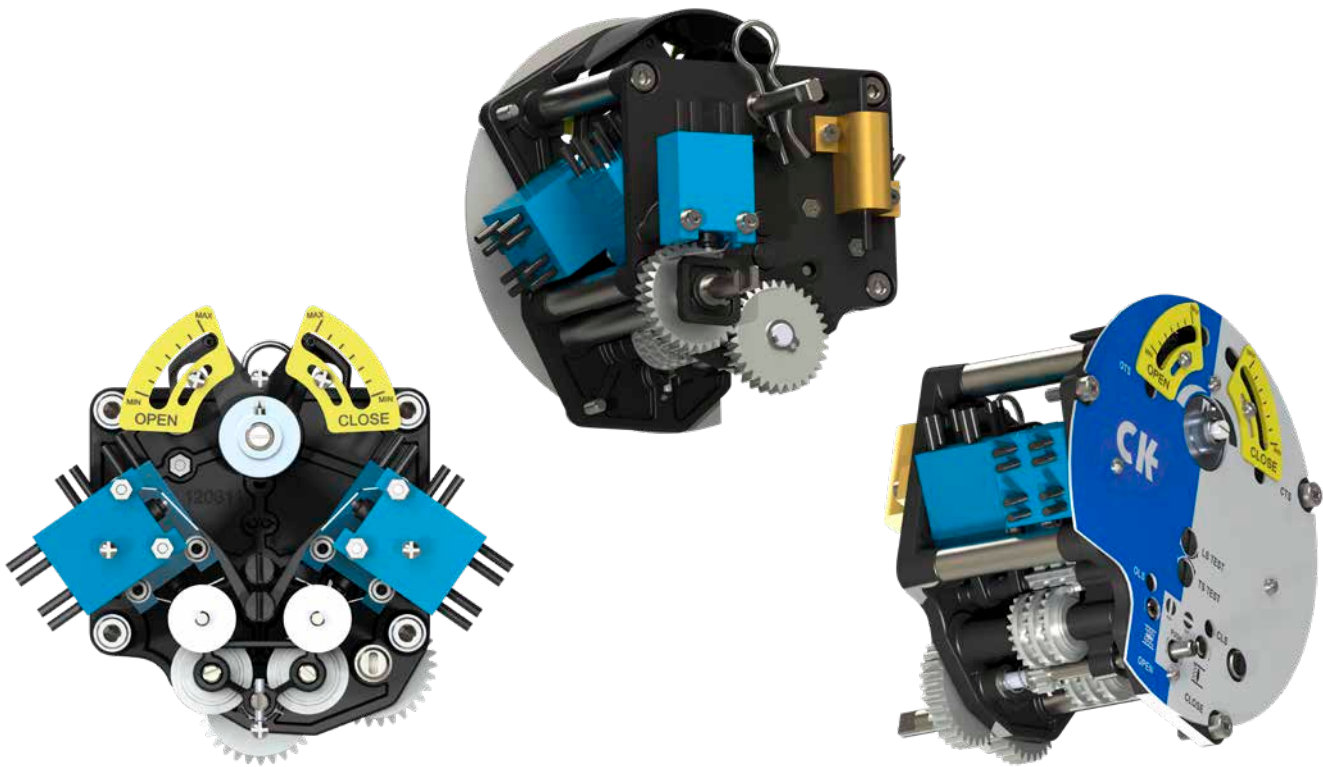

CK Range Mechanical Switch Mechanism (MSM)

CK Switch Mechanisms

Digital Switch Mechanism (DSM)

The DSM is designed exclusively for use with the Centronik control module. Non-intrusive configuration of the actuator position limits and torque trip limits is then possible via the local Centronik display. The DSM consists of a position sensing absolute encoder and torque sensing gear combined into one package.

Position and torque information is processed within the Centronik module for full operational control of the valve or damper. Actuator status information is continuously monitored and recorded digitally in the actuator data logger.

Absolute encoder

Rotork's proven absolute encoder design accurately senses position and torque using only five moving parts. Through the use of multiple gears, Rotork has been able to develop a positioning encoder that incorporates redundancy and self-checking. The orientation of the three position spur gears dictates the current actuator position between the set travel limits, up to 8,000 output turns apart. Torque sensing is performed through an integral sensor providing accurate torque measurement up to rated torque.

Datalogging

Position and torque are monitored at all times during actuator operation. The optional advanced data logger will capture this information and record it in a detailed event log. This can be used for analysis at periodic service intervals or downloaded into the Insight 2 PC software package.



CK Centronik Digital Switch Mechanism (DSM)

Additional Indication Drive (AID)

The optional AID module accompanies a mechanical (MSM) or digital (DSM) switch mechanism to provide additional features that meet various application requirements.

Mechanical position indication

A configurable position disc is included with every AID module. This provides local mechanically driven actuator position at all times, even during actuator power loss.

Analogue signal output

A potentiometric output or loop powered 4-20 mA position transmitter can be included within the AID module to provide analogue position at all times, even during actuator power loss. The potentiometer can also be used in combination with a mechanical switch mechanism to provide intermediate position to a Centronik control module for increased functionality.

Intermediate Position Switches

Two or four intermediate position switches can be provided within the AID module. These are manually adjustable with a simple spring loaded cam design. The switches will continue to function during actuator power loss conditions.



CK Range optional Additional Indication Drive (AID)

Accessibility

Flexible Modularity

The major advantage that a modular actuator concept provides is the ease at which site upgrades can be performed.

Remotely mounted starters

Rotork provide an option to remotely mount the Centronik control module of a CK range actuator. A cable length of up to 100 m (328 ft) enables sufficient access to control module settings where the valve or damper location is restricted by site space constraints.

Rotork module orientation

The plug & socket terminal housing on every CK actuator can be rotated through 360° at 90° increments to best suit the site field wiring requirements. In addition to this, Atronik and Centronik control modules can be rotated in 90° increments at the actuator mating face.

The Atronik and Centronik user interface cover can be rotated through 360° at 90° increments to provide a wide variety of orientation configurations for the best actuation solution.



Remote mounted Centronik controls up to 100m from actuator

Unauthorised Operation Protection

Hand / Auto lever

The hand/auto (manual operation engagement) lever can be padlocked in place, restricting manual operation to authorised personnel only. This suits a padlock with hasp diameter of 6.5 mm.

Local/Stop/Remote selector switch

To prevent unauthorised changes to the actuator operating mode, a latch can be padlocked in place to maintain local, stop or remote operation. This suits a padlock with hasp diameter of 6.5 mm.

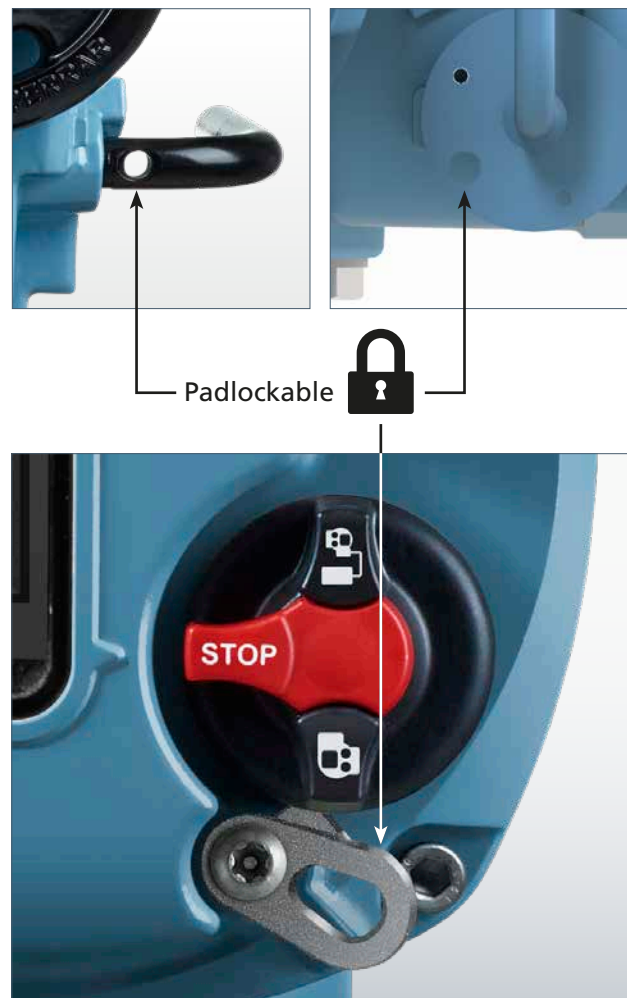

Atronik and Centronik local controls with padlock security feature

Valve Protection and Diagnostics

Rotork actuators have been developed with over 60 years of experience in actuation and comply with global safety standards to provide a reliable actuation solution.

Thermal motor protection

CK range actuators include motor insulation to protect against thermal degradation. Isolating duty actuators (CK, CKA and CKC) include Class F or greater insulation. Modulating duty actuators (CKR, CKRA and CKRC) include Class H insulation. All CK range actuators include self-resetting thermostatic switches embedded into the motor windings to ensure operating temperatures remain within the designed thermal ratings.

Phase rotation correction

All three-phase power supplies for Atronik and Centronik equipped actuators include automatic phase correction to rectify incorrect power cable connection. This is an integral feature to prevent damage to the actuator, improve the ease of commissioning and ensure correct travel direction when receiving operation commands.

Valve overload torque protection

CK range actuators include independently adjustable torque limit switches for both open and close control. Operation will be inhibited should the torque during travel exceed that set with the torque limit switch for the relevant direction. Movement is only permitted in the opposite direction to potentially clear the obstruction and reset the tripped torque switch.

Safe manual operation

The handwheel drive is independent of the motor drive and is selected with a lockable hand/auto lever acting on a slow speed clutch for safe operation. When the motor runs, the actuator automatically returns to motor drive.

Signal loss failure action

CKA, CKRA, CKC and CKRC actuators have the ability to assign a pre-determined function should a loss of control signal occur. This can be configured for an analogue (mA / V) control signal or a network communication signal (digital).

Rising valve stem protection

Cover tube adaptations are available for the CK range to suit all applications. Sizes can be specified in 6" increments depending on valve stem travel. Rotork cover tubes are fully sealed to prevent operator access to the moving stem and provide environmental protection for the valve stem.

Remote operation interlocks

CKC and CKRC actuators include separate interlock signals that can be configured to inhibit operation unless a valid signal is supplied in parallel to the control input.

Centronik security

Configuration via the Centronik module on CKC and CKRC actuators requires a valid password to be entered prior to changing any of the configuration settings.

Secure Bluetooth wireless connection

For Centronik controlled actuators with the optional Bluetooth wireless module, configuration can be performed using a Rotork Setting Tool or Insight 2 PC Software. Both methods require a valid password to be entered to establish a full connection and every Centronik control module is immune to connection by non-Rotork devices or programs.

In order for a site to maintain low cost operation, it is important that operators can monitor each actuator performance and schedule preventive maintenance to maximise up-time. Rotork customers expect CK range actuators to realise three main features: extended service intervals, long service life and reliable operation. All of these attributes aid the customer to achieve a minimal cost of operation.

Self-monitoring

Atronik and Centronik equipped actuators have automatic self-test and diagnosis functions that indicate to the user if any fault state becomes active during operation. The Atronik shows a fault state via the fault indicator LED and Centronik shows a fault state via the LCD display. Both control packages can remotely indicate fault conditions.

Detailed diagnostics

Centronik equipped actuators include the ability to classify fault and alarm status into the four NAMUR categories for remote diagnosis. When an alarm condition becomes active, a maintenance engineer should attend the actuator where detailed status information is provided via the user interface or through Insight 2 PC software. The extra diagnosis information will help to identify the issue and initiate an appropriate rectification action.

Actuator operating attributes

All major actuator operation attributes are monitored and recorded within the on board Centronik data logger. Data for significant attributes such as operating starts, stroke torque and device temperature is collected throughout the lifetime of the actuator.

Event reporting

The Centronik control module can record information regarding warning alarms, failure conditions, operation periods, setting modifications and control command inputs in an event report. This can be used to establish a preventive maintenance scheme to maintain absolute actuator reliability.

Technologically innovative while incorporating proven engineering, Rotork watertight CK range actuators are suitable for all valves in non-hazardous locations.

CK range



Technical Data

The following pages contain performance and specification details for the Rotork CK range of actuators.

Please use the adjacent contents table to help access the information you require.



Section	Page
Motor duty ratings	34
Operating environments	34
Multi-turn CK range actuator performance	36
Supply voltages/mains frequencies	38
Vibration resistance	38
Noise level	38
Design life	39
Motor classification	39
Mounting position	39
Switch mechanism control	39
Mechanical Switch Mechanism (MSM)	40
Additional Indication Drive (AID)	40
Digital Switch Mechanism (DSM)	41
Wiring connections	41
Atronik control module	42
Centronik control module	43

Technical Data

Motor duty ratings

Isolating and modulating duties subject the actuator to different operating loads and mechanical wear trends. For this reason CK range includes CK Standard for isolating duty and CK_R for modulating duty applications. Atronik or Centronik controls can be added to either actuator type to create CKA, CK_{RA}, CK_C and CK_{RC}.

Motor duty ratings are in compliance with ISO 22153 and IEC 60034-1 for all CK range actuators. Further information about actuator outputs and duty cycles is available in the motor classification section on page 39.

Isolating duty actuator model designations to ISO 22153 Class A & B

- CK 30 – CK 500
- CKA 30 - CKA 500
- CK_C 30 – CK_C 500

Modulating duty actuator model designations to ISO 22153 Class C

- CK_R 30 – CK_R 500
- CK_{RA} 30 - CK_{RA} 250
- CK_{RC} 30 – CK_{RC} 500

Operating environments

Rotork actuators are designed for use worldwide in non-hazardous water, power and industrial applications. Focus on making the CK range resistant to the most adverse environments has resulted in exceptional IP68 (8 m / 96 hrs) protection. A good level of environmental protection, wide operating temperature range and extended service intervals provide a versatile actuator suitable for most applications.

Colour

The standard colour is a pale blue - RAL5024. Other colours are available on request, please contact Rotork for more information.

Enclosure protection IP68

Rotork CK range actuators are supplied as standard with IP68 enclosure protection in compliance with EN 60529. The IP68 rating provides protection up to 8 metres submersion for a maximum of 96 hours. Up to 10 operations can be performed whilst the actuator is submerged at the maximum immersion depth. Adequate cable glands must be used to maintain the IP68 integrity of the CK range actuator enclosure. Glands are not supplied as standard with CK actuators. In order to maintain IP68 enclosure integrity during service down time periods, an optional CK socket field parking housing can be used to cover unmated module faces.

Lubrication

CK range actuators are factory filled for life with premium quality gear oil selected for the application. Standard oil is automotive grade, easily available worldwide. Oil lubrication out-performs grease over a wide temperature range and allows installation in any orientation. It has none of the problems associated with grease such as separation at elevated temperatures and "tunneling" at lower temperatures, where grease is thrown away from rotating components creating a void or tunnel in the grease around components that require lubrication. Standard oil is automotive grade SAE80EP. Low temperature oil is MOBIL SHC624. Food grade oil is Hydra Lube GB Heavy.

Corrosion protection

Corrosion protection is a vital part of a reliable actuation solution to ensure a long service life is achieved for the product. All CK range actuator finishes are tested in accordance with Rotork 1,000 hour cyclic salt spray test procedure which is the most realistic and arduous test cycle applicable. The test combines cyclic salt spray, drying and humidity at elevated temperatures on complete factory built actuators. This procedure is designed to test the finish coatings and the various substrate materials, fixings and interfaces on an actuator. Substrate materials and finishes are selected to provide maximum corrosion resistance combined with good adhesion.

Corrosivity category	CK paint solution	Exterior environment	Interior environment
C1	Standard RAL5024 powder coat (P1)	N/A	Heated buildings with clean atmospheres e.g. offices, shops, schools and hotels.
C2		Atmospheres with low levels of pollution, e.g. rural areas.	Unheated buildings where condensation may occur, e.g. depots and sports halls.
C3		Urban and industrial atmospheres, moderate SO ₂ pollution, e.g. city centres and coastal areas with low salinity.	Production rooms with high humidity and some air pollution, e.g. food processing plants, laundries, breweries and dairies.
C4	Standard RAL5024 powder coat plus offshore coating on ferrous materials (P2)	Industrial and coastal areas with moderate salinity, e.g. coastal ship and boatyards.	Areas with permanently aggressive atmospheres, e.g. chemical plants and swimming pools.
C5-M (Marine)		Coastal and offshore areas with high salinity, e.g. offshore rigs and boats.	Areas with extremely aggressive atmospheres containing high humidity, salinity and pollutant concentration, e.g. cooling towers and boats.
C5-I (Industrial)		Industrial areas with high humidity and aggressive atmospheres, e.g. water treatment plants and power stations.	Areas with extremely aggressive atmospheres containing high humidity and high pollutants, e.g. chemical plants and boiler houses.

The above table details paint protection levels up to 15 years durability as per ISO12944-2.

Technical Data

Ambient temperatures

CK range actuators can accommodate a variety of operating temperature requirements that will ensure successful actuation in the harshest non-hazardous environments. The optional low temperature CK build involves replacement seals, lubrication and bearings. Values shown in the below table apply to all variants of CK range actuators including Atronik and Centronik control modules.

Type	Version	Temperature range	
		Operating temperature	Storage temperature
Multi-turn isolating duty 3-phase CK actuators	Standard	-30 to +70 °C (-22 to +158 °F)	-40 to +80 °C (-40 to +176 °F)
	Optional	-40 to +60 °C (-40 to +140 °F)	-60 to +80 °C (-76 to +176 °F)
Multi-turn isolating duty 1-phase CK actuators	Standard	-25 to +70 °C (-13 to +158 °F)	-40 to +80 °C (-40 to +176 °F)
Multi-turn modulating duty 3-phase CK actuators	Standard	-30 to +70 °C (-22 to +158 °F)	-40 to +80 °C (-40 to +176 °F)
	Optional	-40 to +60 °C (-40 to +140 °F)	-60 to +80 °C (-76 to +176 °F)

Actuator Fixings

Frame Size		Unit	CK 30 & CK 60		CK 120	CK 250 & CK 500
Type 'A' Coupling	Flange size (ISO5210)	-	F07	F10	F10	F14
	Flange size (MSS SP -102)	-	FA07	FA10	FA10	FA14
	Stem acceptance rising*	mm (in)	26 (1)	34 (1 ¹ / ₃)	40 (1 ⁵ / ₈)	57 (2 ¹ / ₄)
	Maximum axial thrust	kN (lbf)	40 (8,992)	40 (8,992)	70 (15,737)	160 (35,969)
	Stem acceptance non-rising*	mm (in)	20 (3/4)	26 (1)	32 (1 ¹ / ₄)	45 (1 ³ / ₄)
Type 'B' Coupling	Type 'B1' (fixed bore)	mm (in)	28 (1 ¹ / ₈)	42 (1 ⁵ / ₈)	42 (1 ⁵ / ₈)	60 (2 ³ / ₈)
	Type 'B3' (fixed bore)	mm (in)	16 (5/8)	20 (3/4)	20 (3/4)	30 (1 ¹ / ₈)
	Type 'B4' (blank)*	mm (in)	20 (3/4)	30 (1 ¹ / ₈)	30 (1 ¹ / ₈)	45 (1 ³ / ₄)

* This coupling type requires machining to match the valve or gearbox stem. Dimensions given for this coupling are maximum values.

Technical Data

Multi-turn CK range actuator performance

Isolating duty CK, CKA & CKc – 3-phase

The following data is valid for actuators with 3-phase AC motors operated with a Class A & B (ISO 22153) / S2 – 15 minutes (IEC60034-1) duty rating. For further details of the actuator electrical specification, refer to the applicable CK electrical data sheet.

Size	Torque				RPM (at 50 Hz)	RPM (at 60 Hz)	Hand Wheel Ratio	Actuator Output Flange	
	Maximum		Operational					ISO 5210	MSS SP-102
	Nm	lbf.ft	Nm	lbf.ft					
CK 30	30	22	10	7	9, 12, 18, 24, 36, 48, 72, 96, 144	11, 14, 21, 29, 43, 57, 86, 115, 173	10:1	F07/F10	FA07/ FA10
	25	18			192	230			
CK 60	60	44	20	15	9, 12, 18, 24, 36, 48, 72, 96, 144	11, 14, 21, 29, 43, 57, 86, 115, 173	10:1	F07/F10	FA07/ FA10
	50	37			192	230			
CK 120	120	89	40	30	9, 12, 18, 24, 36, 48, 72, 96, 144	11, 14, 21, 29, 43, 57, 86, 115, 173	10:1	F10	FA10
	100	74			192	230			
CK 250	250	184	83	61	9, 12, 18, 24, 36, 48, 72, 96, 144	11, 14, 21, 29, 43, 57, 86, 115, 173	10:1	F14	FA14
	200	148			192	230			
CK 500	500	369	167	123	9, 12, 18, 24, 36, 48, 72, 96*, 144*	11, 14, 21, 29, 43, 57, 86, 115*, 173*	20:1	F14	FA14
	400	295			192*	230*			

Note: Torque rating is maximum torque setting in both directions. Stall torque will be an average of 1.4 to 2.0 times this value depending on speed and voltage.

Note: Due to the effects of inertia and drive nut wear, 144 & 192 RPM speeds are not recommended for direct mounted gate valve applications.

* CK and CKc actuators only.

Isolating duty CK, CKA & CKc – 1-phase

The following data is valid for actuators with 1-phase AC motors operated with a Class A & B (ISO 22153) / S2 – 15 minutes (IEC 60034-1) duty rating. For further details of the actuator electrical specification, refer to the applicable CK electrical data sheet.

Size	Torque				RPM (at 50 Hz)	RPM (at 60 Hz)	Hand Wheel Ratio	Actuator Output Flange	
	Maximum		Operational					ISO 5210	MSS SP-102
	Nm	lbf.ft	Nm	lbf.ft					
CK 30	30	22	10	7	24, 36, 48, 72, 96, 144	29, 43, 57, 86, 115, 173	10:1	F07/F10	FA07/ FA10
	25	18			192	230			
CK 60	60	44	20	15	18, 24, 36, 48, 72, 96, 144	21, 29, 43, 57, 86, 115, 173	10:1	F07/F10	FA07/ FA10
	50	37			192	230			
CK 120	120	89	40	30	18, 24, 36, 48, 72, 96, 144*	21, 29, 43, 57, 86, 115, 173*	10:1	F10	FA10
	100	74			192*	230*			
CK 250	250	184	83	61	18, 24, 36, 48	21, 29, 43, 57	10:1	F14	FA14

* 110V and 115V is not available for this actuator size and speed combination.

Technical Data

Regulating / Modulating duty CK_R, CK_{RA} & CK_{RC} – 3-phase 25%

The following data table is valid for actuators with 3-phase AC motors operated with a Class C (ISO 22153) / S4 – 25% (IEC 60034-1) duty rating. For further details of the actuator electrical specification, refer to the applicable CK electrical data sheet.

Size	Torque				Max. Starts	RPM (at 50 Hz)	RPM (at 60 Hz)	Hand Wheel Ratio	Actuator Output Flange	
	Maximum		Modulating						ISO 5210	MSS SP-102
	Nm	lbf.ft	Nm	lbf.ft						
CK_R 30	30	22	15	11	600	9, 12, 18, 24, 36, 48, 72, 96	11, 14, 21, 29, 43, 57, 86, 115	10:1	F07/F10	FA07/FA10
CK_R 60	60	44	30	22	600	9, 12, 18, 24, 36, 48, 72, 96	11, 14, 21, 29, 43, 57, 86, 115	10:1	F07/F10	FA07/FA10
CK_R 120	120	89	60	44	600	9, 12, 18, 24, 36, 48, 72, 96	11, 14, 21, 29, 43, 57, 86, 115	10:1	F10	FA10
CK_R 250*	250	184	120	89	600	9, 12	11, 14	10:1	F14	FA14
					600	18, 24	21, 29			
					600	36, 48	43, 57			
					400	72, 96	86, 115			
CK_R 500*	500	369	200	148	600	9, 12	11, 14	20:1	F14	FA14
					600	18, 24	21, 29			
					600	36, 48	43, 57			
					400	72, 96	89, 115			

* CK_{RA} 250 is only available from 9 - 14 rpm. CK_{RA} 500 is not available.

Regulating / Modulating duty CK_R & CK_{RC} – 3-phase 50%

The following data table is valid for actuators with 3-phase AC motors operated with a Class C (ISO 22153) / S4 – 50% (IEC 60034-1) duty rating. For further details of the actuator electrical specification, refer to the applicable CK electrical data sheet.

Size	Torque				Max. Starts	RPM (at 50 Hz)	RPM (at 60 Hz)	Hand Wheel Ratio	Actuator Output Flange	
	Maximum		Modulating						ISO 5210	MSS SP-102
	Nm	lbf.ft	Nm	lbf.ft						
CK_R 30	30	22	10	7	1200	9, 12, 18, 24, 36, 48, 72, 96	11, 14, 21, 29, 43, 57, 86, 115	10:1	F07/F10	FA07/FA10
CK_R 60	60	44	20	15	1200	9, 12, 18, 24, 36, 48, 72, 96	11, 14, 21, 29, 43, 57, 86, 115	10:1	F07/F10	FA07/FA10
CK_R 120	120	89	45	33	1200	9, 12, 18, 24, 36, 48, 72, 96	11, 14, 21, 29, 43, 57, 86, 115	10:1	F10	FA10
CK_R 250	250	184	90	66	1200	9, 12	11, 14	10:1	F14	FA14
					900	18, 24	21, 29			
					600	36, 48	43, 57			
					400	72, 96	86, 115			
CK_R 500	500	369	180	133	1200	9, 12	11, 14	20:1	F14	FA14
					900	18, 24	21, 29			
					600	36, 48	43, 57			
					400	72, 96	89, 115			

Technical Data

Supply voltages / mains frequencies

Compatible power supplies for CK range actuators are shown below. Not all actuator versions or sizes are available with all motor types or voltages/frequencies. For detailed information please refer to the separate electrical data sheets.

3-phase AC Isolating Duty

Voltages	Frequency
[V]	[Hz]
220, 240, 380, 400, 415, 440, 500	50
220, 240, 380, 440, 460, 480, 600	60

1-phase AC Isolating Duty

Voltages	Frequency
[V]	[Hz]
110, 115, 220, 230, 240	50
110, 115, 220, 230, 240	60

3-phase AC Modulating Duty

Voltages	Frequency
[V]	[Hz]
220, 240, 380, 400, 415, 440	50
220, 240, 380, 440, 460, 480	60

Permissible power supply tolerances for voltage and frequency

For all CK range actuators:

- Voltage tolerance $\pm 10\%$
- Frequency $\pm 5\%$
- Maximum starting Volt drop - 15%

Vibration resistance

According to EN 60068-2-6, EN 60068-2-27

Type	Level
Plant induced vibration	CK, CKR, CK remote mount actuator body only: 2g RMS total for all vibration within the frequency range 10 to 1,000 Hz.
	CKA, CKc: 1g RMS total for all vibration within the frequency range 10 to 1,000 Hz.
Shock	CK all configurations: 5g peak acceleration
Seismic	CK all configurations: 2g over a frequency range of 1 to 50 Hz if it is to operate during and after the event
	CK all configurations: 5g over a frequency range of 8 to 50 Hz if it is only required to maintain structural integrity

Noise level

The noise level originated by the multi-turn CK actuator range does not exceed 70 dB(A) at a distance of 1 m under normal operating conditions.



Technical Data

Design life

According to ISO 22153

An actuator start is any operation that requires the motor to start movement in either direction. If the motor is already moving and a command to operate in the same direction is applied this will not count as a start.

Actuators for isolating duty

Type	Design life rating
CK, CKA, CKc	500,000 output turns, seating at rated torque, 33% rated torque through stroke

Actuators for modulating duty – 25%

Type	Design life rating
CKR, CKRA, CKRc	1,200,000 starts* at a minimum of 50% rated torque, minimum 1% stroke movement

Actuators for modulating duty – 50%

Type	Design life rating
CKR, CKRc	1,200,000 to 1,800,000 starts* at a minimum of 30% rated torque, minimum 1% stroke movement

* Number of starts determined by actuator output torque as per ISO 22153.

Motor classification

Type of duty according to IEC 60034-1 / ISO 22153

Type	3-phase AC	1-phase AC
CK 30 – CK 500	S2 – 15 min, S2 – 30 min / Classes A, B	S2 – 15 min / Classes A, B
CKA 30 – CKA 500	S2 – 15 min, S2 – 30 min / Classes A, B	S2 – 15 min / Classes A, B
CKc 30 – CKc 500	S2 – 15 min, S2 – 30 min / Classes A, B	S2 – 15 min / Classes A, B
CKR 30 – CKR 500*	S4 – 25%, S4 – 50% / Class C	–
CKRA 30 – CKRA 250*	S4 – 25% / Class C	–
CKRc 30 – CKRc 500*	S4 – 25%, S4 – 50% / Class C	–

Information on motor duty type is subject to the following conditions: nominal supply voltage, +40 °C (+104 °F) ambient temperature and average load of 33% rated torque.

* High speed CKR, CKRA & CKRc actuators have a reduced duty cycle to reduce wear on the actuator drive train. Please refer to the multi-turn CK range actuator performance data for details of duty cycle restrictions.

Rated values for motor protection

As standard, thermo switches are used for motor protection against excessive heat rise. When an Atronik or Centronik control module is equipped, the motor protection signals are processed internally to initiate an alarm status within the actuator. This will prevent further operation until the thermo switch has reset within the correct operating band. Signals in the CK and CKR must be analysed with external controls.

Mounting position

CK range actuators (with or without control module) can be operated without restriction in any mounting orientation.

Switch mechanism control

Valve travel limit span

Actuator	Possible valve travel (turns)	
	Mechanical switch mechanism	Digital switch mechanism
CK, CKA, CKc	1,500	8,000

Mechanical switch mechanism

The mechanical switch mechanism is internally wired to accommodate an external control system. The terminals used for various functions are specified in the actuator wiring diagram and terminal plan. All connections are via the Rotork plug and socket system for simple actuator site integration. Mechanical switch mechanism is compatible with Atronik and Centronik control modules.

Digital switch mechanism – CKc & CKRc only

The digital switch mechanism is designed to measure position and torque with encoder technology. The position and torque values are then transmitted via CAN bus to the attached Centronik control module for further processing. Position and torque limit switches are digitally set through the integral Centronik software. Digital switch mechanism is only compatible with Centronik control modules.

Technical Data

Mechanical Switch Mechanism (MSM)

Position and torque limit switches

Selection	Description	Contact type
Standard – 4 switches	2 position switches - 1 for each direction 2 torque switches - 1 for each direction	Each 4-wire switch has a NO and NC contact, sealed to IP67
Optional – 6 switches	4 position switches - 2 for each direction (standard plus additional switches) 2 torque switches - 1 for each direction	Each 4-wire switch has a NO and NC contact, sealed to IP67
Optional – 6 switches	2 position switches - 1 for each direction 4 torque switches - 2 for each direction (standard plus additional switches)	Each 4-wire switch has a NO and NC contact, sealed to IP67
Optional – 8 switches	4 position switches - 2 for each direction (standard plus additional switches) 4 torque switches - 2 for each direction (standard plus additional switches)	Each 4-wire switch has a NO and NC contact, sealed to IP67

Electrical rating				Switch details		
Switch voltage	30 V	125 V	250 V	Functionality	Contact type	Contact material
AC inductive load (cos Ø > 0.8)	5 A	5 A	5 A	4 wire - Lever action	2 snap action contacts	Silver
DC resistive load	0.5 A	0.5 A	0.5 A			

Blinker contact for movement indication

Electrical rating				Blinker transmitter details		
Switch voltage	30 V	125 V	250 V	Functionality	Contact type	Contact material
AC inductive load (cos Ø > 0.8)	5 A	5 A	5 A	2 wire – Rotation of indented cam	1 snap action contact	Silver
DC resistive load	0.5 A	0.5 A	0.5 A			

Additional Indication Drive (AID)

Intermediate position switches

Electrical rating				Switch details		
Switch voltage	30 V	125 V	250 V	Functionality	Contact type	Contact material
AC inductive load (cos Ø > 0.8)	5 A	5 A	5 A	2 wire – Lever action	1 snap action contact	Silver
DC resistive load	0.5 A	0.5 A	0.5 A			

Intermediate position indication

Precision potentiometer	
Linearity	≤ 2 %
Power	0.5 W
Resistance (standard)	5 kΩ
Resistance (optional)	1 kΩ, 10 kΩ

Electronic remote position transmitter (CPT)	
Connection	3/4 wire
Signal range	4-20 mA
Power supply	24 VDC, ±15 % smoothed

Technical Data

Digital Switch Mechanism (DSM)

Operating features	
Position measurement	Multiple gear assembly (1 driving gear and 3 measurement gears) sensing position using hall effect sensor technology
Torque measurement	Single direct drive gear assembly sensing torque using hall effect sensor technology

Wiring connections

Plug and socket

Rotork Plug & Socket connector			
Detail	Motor contacts	Protective earth	Control contacts
Max. no. of contacts	3	1	52
Designation	1, 2, 3	PE	4-56
Max. rated current	20 A	-	5 A
Customer connection type	Screw	Ring Tag	Screw
Max. cross section	6 mm ²	M4 Ring Tag	2.5 mm ²
Pin socket carrier material	Polyamide	Polyamide	Polyamide
Contact material	Brass	Brass	Brass – Tin Plated

Conduit entries

Terminal housing conduit entry thread details	
Metric threads (standard)	1 x M20 x 1.5p, 1 x M25 x 1.5p, 1 x M32 x 1.5p
NPT – threads (option)	2 x ¾" NPT, 1 x 1¼" NPT

Optional terminal housing conduit entry thread details	
Metric threads	1 x M20 x 1.5p, 2 x M25 x 1.5p, 1 x M32 x 1.5p
NPT – threads	1 x ¾" NPT, 2 x 1" NPT, 1 x 1¼" NPT
Blank casting	Subject to third party machining

Disconnect module terminal housing conduit entry thread details	
Metric threads	2 x M25 x 1.5p, 4 x M20 x 1.5p
NPT – threads	2 x 1" NPT, 4 x ¾" NPT

Technical Data

Atronik control module

Electrical features	
Digital input signals	
Standard	24 VDC; OPEN, STOP/MAINTAIN, CLOSE, ESD
Intermediate position set point control	
Optional analogue input	4-20 mA , 0-5 V, 0-10 V
Output signals	
Standard monitor relay	1 potential free change over contact, maximum 24 VDC, 2 A / 250 VAC, 0.5 A
Standard S1-S2 relays	2 output contacts with user defined trigger conditions, potential free contacts, normally open (N/O) contact form, maximum 24 VDC, 2 A / 250 VAC, 0.5 A
Optional S3-S6 relays	4 additional output contacts with user defined trigger conditions, potential free contacts, normally open (N/O) contact form, maximum 24 VDC, 2 A / 250 VAC, 0.5 A
Intermediate position feedback	
Optional analogue output	4-20 mA
Local controls	
Standard local controls	Lockable local selector switch: LOCAL, STOP, REMOTE Operation switch: OPEN, CLOSE
Optional vandal resist	Physical lockable cover - preventing access to controls and indication.

Technical Data

Centronik control module

Electrical features	
Digital input signals	
Standard	24 VDC; OPEN, STOP/MAINTAIN, CLOSE, ESD, OPEN INTERLOCK, CLOSE INTERLOCK
Option	115 VAC; OPEN, STOP/MAINTAIN, CLOSE, ESD, OPEN INTERLOCK, CLOSE INTERLOCK
Intermediate position set point control	
Optional analogue input	4-20 mA, 0-5 V, 0-10 V, 0-20 V
Output signals	
Standard monitor relay	1 potential free change over contact, maximum 30 VDC / 150 VAC, 5 A
Standard S1-S4 relays	4 output contacts with user defined trigger conditions, potential free contacts, configurable contact form, maximum 30 VDC / 150 VAC, 5 A
Optional S5-S8 relays	4 additional output contacts with user defined trigger conditions, potential free contacts, configurable contact form, maximum 30 VDC / 150 VAC, 5 A
Intermediate position feedback	
Optional analogue output	4-20 mA
Intermediate torque feedback	
Optional analogue output	4-20 mA (requires DSM)
Local controls	
Standard local controls	Lockable local selector switch: LOCAL, STOP, REMOTE Operation/Navigation switch: OPEN/+, CLOSE/-
Optional vandal resist	Software setting (fixed LOCAL or REMOTE) - selector position ignored. Physical lockable cover - preventing access to controls and display.
Back up supply	
Auxiliary power supply option	Maintain power to Centronik control module on loss of main power supply. Nominal 24 VDC, 1 A (switching inrush 8 A max). 3 mA draw with mains power, 100 mA draw without mains power. Customer supply is not available whilst the Centronik is powered by the auxiliary source.
Speed control	
Interrupter Timer	Timer feature to pulse movement over a portion of travel - configurable travel, direction, on and off pulse duration.

Approvals

CK range electric actuators have been designed to meet the following approval procedures:

BS and DIN standards

CK range actuators comply with ISO 22153, Industrial valves - Actuators - Part 2: Electric actuators for industrial valves - Basic requirements.

CSA

CK, CKA, CKc actuators are approved by CSA. Refer to certificate 70021797.

Actuator drive couplings

The CK range features a removable coupling for all sizes. All base dimensions and couplings comply with ISO 5210 or MSS SP-102 for multi-turn CK.

LVD compliance

CK range actuators comply with Directive 2014/35/EU and SI 2016 No. 1101, safety requirements for electrical equipment for measurement, control and laboratory use: General requirements, to demonstrate compliance with this directive.

The following installation assumptions are used to derive the requirements:

- Pollution Degree 2
- Category II Overvoltage Installation Locations
- Actuator installed up to 2,000 metres

Machinery directive

Compliance with the following European Economic Community and UK Statutory Instruments (SI) Directives permits CK range actuators to be CE marked under the provision of the Machinery Directive. See table below:

Directive	Applicable to	Reference
Electromagnetic compatibility (EMC)	Immunity to / emissions of electromagnetic energy	Directive 2014/30/EU and SI 2016 No. 1091
Electrical Safety (LVD)	Electrical safety	Directive 2014/35/EU and SI 2016 No. 1101
Machinery (Safety) ¹	Product safety	Actuators follow the provision of the Machinery Directive 2006/42/EC and SI 2008 No. 1597. The CK must not be put into service until the equipment into which it is being incorporated has been declared to be in conformity with the provisions of the European Community Machinery Directive 2006/42/EC and SI 2008 No. 1597.
Radio Equipment	Bluetooth modules - actuator and Rotork Bluetooth® Setting Tool Pro	Directive 2014/53/EU and SI 2017 No. 1206
Waste Electrical Equipment (WEE)	Exempt under the scope of the directive	
Federal Communications Commission	Bluetooth modules - actuator and Rotork Bluetooth® Setting Tool Pro	Contains FCC certified transmitter module.

Note:





- ¹ Actuators are not classified as machines within the scope of the machinery directive. Contact Rotork for a copy of our Declaration of Conformity and Incorporation.

Manual handwheel operation

Handwheel size and mechanical advantage are generally designed in accordance with standard EN 12570 to give the most efficient compromise of force and turns for emergency operation. Handwheels and adaptations can be provided to meet AWWA specifications.

NAMUR 107 compatibility

CK actuators equipped with the Centronik module provide feedback for alarm statuses in accordance with NAMUR 107 guidelines.

-  Failure – the actuator has experienced a failure condition and may not respond to remote control commands.
-  Function check – the actuator settings are being adjusted and is therefore unavailable for operation.
-  Out of specification – the actuator will recognise a process condition that does not match the configured setting value. Operation can commence during this alarm state.
-  Maintenance required – the actuator must be examined by a service technician to evaluate maintenance requirements. Operation can commence during this alarm state.

Functions

CK and CK_R actuators may require additional external wiring to achieve functions listed below.

Actuator model	CK & CK _R	CKA & CK _{RA}	CKc & CK _{Rc}
Control module	None	Atronik	Centronik
Protection features			
Automatic phase rotation correction		Standard	Standard
Valve overload torque protection	Standard – wiring	Standard	Standard
Control circuit current protection		Standard	Standard
Motor thermal protection	Standard – wiring	Standard	Standard
Heater	Standard	Standard	Standard
Control functions			
Manual operation	Standard	Standard	Standard
Configurable seating action	Standard – wiring	Standard – switch	Standard – software
Positioner (analogue control)		Option	Option
Loss of signal action		Option	Option
Stop at intermediate position	Option	Standard	Standard
Interrupter Timer			Option
Configurable ESD action		Standard	Standard
Torque limit by-pass	Standard – wiring	Standard – switch	Standard – software
Network interface control		Option	Option
Monitoring functions			
Phase failure detection		Standard	Standard
Phase sequence detection		Standard	Standard
Manual operation detection		Standard	Standard
Motion detection	Standard	Standard	Standard
Network interface feedback		Option	Option
Signal loss detection		Option	Option
Local position limit feedback	Option	Standard	Standard
Local intermediate position feedback	Option	Standard	Standard
Remote position limit feedback	Standard	Standard	Standard
Remote intermediate position feedback	Option	Option	Option
NAMUR NE107 status categories			Standard
Data logging and analysis			
Attribute event recording			Standard
Time-stamped event recording			Option
Asset management information			Standard
Asset management analysis data			Option
Electronic Bluetooth device ID			Option

Site Services

Rotork understand the value of prompt, punctual and superior site services. Rotork Site Services have specialist expertise, insight and experience in service support for mission-critical flow control and instrumentation solutions for oil and gas, water and wastewater, power, chemical process and industrial applications. We offer global frontline support backed by dedicated in-house experts.

Our service solutions increase plant efficiency and reduce maintenance costs, while workshop services return equipment to as-new condition. Our experience and understanding of the flow control industry means we have extensive insight and ideas of what we can do to provide significant value to our customers and their operations.

Rotork Site Services is comprised of two main areas; Lifetime Management and Site Services. Lifetime Management is the suite of services within Rotork Site Services which help you manage the risk associated with aging assets and includes our Reliability Services offering. Site Services comprises essential actuator service, repair, maintenance and upgrades.

Rotork has specialist expertise, insight and experience in flow control.

We provide insight into how we can deliver value to our customers.

Our service solutions increase plant efficiency and reduce maintenance costs.



Site Services

Lifetime Management

The services available within Lifetime Management offer a complete solution to managing the risks associated with the life cycle of your equipment and their obsolescence (which compromise reliable performance and valuable uptime).

The aim of Lifetime Management is to provide you with constant support and minimum- to- no disruption to your production flow. It is a customisable service offering designed to seamlessly maintain and improve your assets. We manage the inherent risks associated with advances in technology, component obsolescence and ageing equipment for you. We are committed to helping customers maximise the continuous, fault-free operation and working life of their actuators. Supporting the continuous and reliable operation of your plant allows for improved performance and increases in valuable uptime.

Lifetime Management covers:

- Reliability Services
 - Health Check
 - Planned Maintenance
 - Enhanced Warranty
 - Predictive Maintenance
- Upgrade Services (retrofit)
- Planned Shutdown Support (service or run time)
- Life Cycle Services (based on years in service or run time)
- Overhauls/Refurbishment
- Customised Spares Programme
- Training
- Consultancy



Site Services

Rotork's Site Services comprises the essential on-site actuator service, repair, maintenance and upgrades part of our service offering, plus the commissioning of new actuators and applications. It includes off-site work completed at a Rotork Support Centre including recertification, automation, testing and product selection.

Our decades of experience in the industrial actuation and flow control markets means that customers can rely on us to understand their problems and to deliver reliable, economic solutions. Rotork's talented and experienced engineers have an in-depth understanding of the problems that are faced in the field and they know how to fix them.

On sites where providing evidence of valid asset certification is a legal requirement, Rotork engineers can carry out the necessary OEM level inspections and provide the statutory paperwork to comply with regulations.

- Planned Shutdown Support
- Actuator Workshop Overhaul
- Field Support
- Valve Automation Services
 - On-site
 - Off-site
- Global Support



rotork®



www.rotork.com

A full listing of our worldwide sales and service network is available on our website.

Rotork plc
Brassmill Lane, Bath, UK
tel +44 (0)1225 733200
email mail@rotork.com

PUB111-001-00
Issue 02/22

As part of a process of on-going product development, Rotork reserves the right to amend and change specifications without prior notice. Published data may be subject to change. For the very latest version release, visit our website at www.rotork.com

The name Rotork is a registered trademark. Rotork recognises all registered trademarks. The Bluetooth® word mark and logos are registered trademarks owned by Bluetooth SIG, Inc. and any use of such marks by Rotork is under license. Published and produced in the UK by Rotork. POLTG0322